



### Specifications:

Heavy-duty range match fryer , 20 kW with 70 Lb. (31kg) shortening capacity. Overall dimensions are 24" (610mm) W x 36" (914mm) H x 36" (914mm) D, with a heavy gauge, continuously welded nickel-plated fry tank. Utilizes four fixed immersion type inconel elements positioned to provide heat to the sides, back, front and bottom of the frying area. Fryer is standard with stainless steel front and black powder coat epoxy side, mounted on storage cabinet complete with door.. All controls are mounted at a convenient level on the switch panel. Fryers are available with casters or for dais mount.

### Standard Features:

- Stainless steel front w/black powder coat epoxy sides
- 20kW total element package.
- 70 Lb. (31 kg) shortening capacity, continuously welded, heavy gauge nickel-plated steel-fry tank. 1" (25mm) drain valve is located at the bottom
- chrome wire basket
- Electromechanical thermostat with temperature control range of 200°F (93°C) to 375°F (190°C)
- Inconel immersion type fixed heating elements
- 6" (152mm) adjustable chrome plated legs (NSF)
- 1 year warranty parts & labor (USA & Canada)

### Optional Features:

- Stainless steel sides & main back
- Stainless steel tank cover
- Extra fry tank
- Extra fry tank w/manual filter & 1" drain valve
- Set of twin baskets
- Large single basket
- 6" (152mm) adjustable stainless steel legs
- High voltage 460V
- 4 swivel casters complete with front brakes

NOTE: The fryers may be paired together to form a common unit. They may be paired with a frymate model or may be set up as frystations of two fryers with a frymate unit between them. These fryers are designed to battery with 36E series heavy-duty ranges.

NOTE: Fryers supplied with casters must be installed with an approved restraining device.





Item #: \_\_\_\_\_

Model: 36ES21

Product Name: 36E Series Heavy Duty Fryer

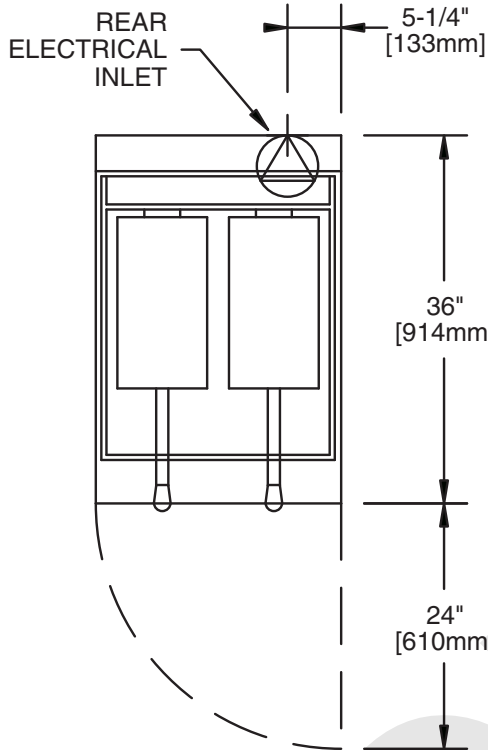

Model	Nominal Ampers Per Line											
	1 Phase			Three Phase								
	208	240	460	208			240			460		
			X	Y	Z	X	Y	Z	X	Y	Z	
36ES21	96	85	43	60	44	64	54	39	57	28	20	29

Model	Total KW	Three Phase KW per Phase		
		208, 240, 460		
		X-Y	Y-Z	X-Z
36ES21	20	4.8	5.6	9.6

Available Voltages: 208 VAC (197-219); 240 VAC (220-240); 460 VAC (440-480). When ordering specify voltage and phase.

Garland products are not approved or authorized for home or residential use, but are intended for commercial applications only. Garland will not provide service, warranty, maintenance or support of any kind other than in commercial applications.

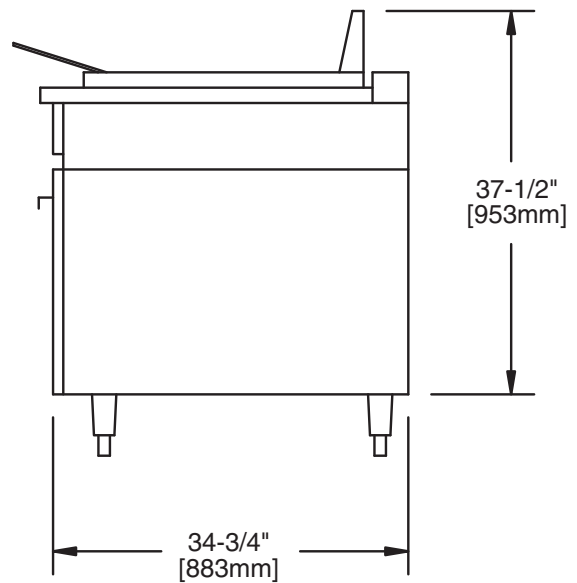
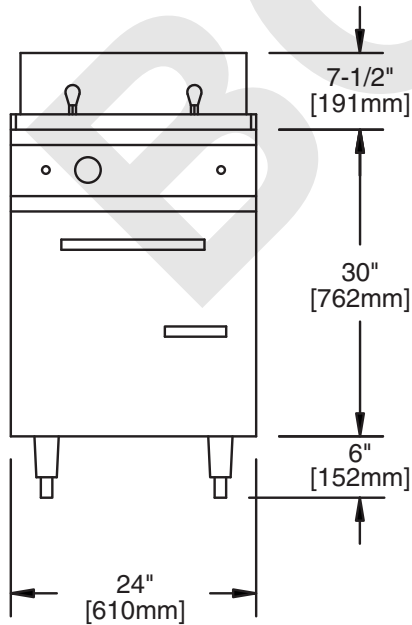

Continuous product improvement is a Garland policy.