



Item #: _____

Models: M48R, M48S, M48T

Product Name: Master Series Thermostat
Controlled Griddle-Top Range



Standard Features:

- Stainless steel front; black powder coat epoxy sides
- 6" (152mm) chrome steel adjustable legs 7-1/2" (191mm) stainless steel front rail
- 1" (25mm) thick steel griddle plate
- 2-5/16" (591mm) high welded steel splash guard, sides and back
- Clip-on stainless steel backsplash
- Removable front-mounted stainless steel grease receptacle
- Thermostatic control for each griddle burner
- Three "H" griddle burners 99,000 BTU total. (29 kW)
- Piezo spark ignition for oven
- Fully porcelainized oven interior
- Storage base interior of aluminized steel w/shelf, (model M48S)
- Modular top section, (model M48T)
- 40,000 BTU (11.7 KW) cast iron oven burner
- One year limited warranty, (USA & Canada only)

Optional Features:

- Stainless steel left, right or both sides
- Stainless steel main back
- Stainless steel common front rail up to 68" (1728mm) wide (two or more units in a battery)
- Stainless steel oven interior
- Convection oven base, add C to Model No., e.g. M48RC
- Additional oven rack
- Rear gas connection, 3/4" or 1" NPT
- End caps and cover, (no charge)-Must specify
- Swivel casters (4) w/front brakes
- Polyurethane non-marking swivel casters (4) w/front brakes
- 6" (152mm) stainless steel adjustable legs
- 4" (102mm) chrome steel adjustable legs
- Toe base (not for use with "RC" oven hale)
- Storage base shelf of aluminized or stainless steel
- Single deck stainless steel tubular high shelf
- Double deck stainless steel tubular high shelf
- 10" (254mm) high stainless steel backguard
- 17" (432mm) high stainless steel backguard
- 33" (838mm) high stainless steel backguard
- Stainless steel vertical flue riser, 13"W x 33"H, (330mm x 839mm)
- 230 volt, 50 cycle components, RC motor and/or electric ignition (export)
- Celsius dial for oven thermostat (no charge)

NOTE: Ranges supplied with casters must be installed with an approved restraining device.

Specification:

Heavy-duty gas range with oven, Model M48R. One 34" (864mm wide thermostat controlled griddle. 1" (25mm) thick, 99,000 BTU (29 kW) total. 34" (864mm) wide x 38" (965mm) deep, including 7 1/2" (191mm) deep stainless steel front rail. Porcelain enamel oven interior measuring 26 1/4" (667mm) wide x 13 1/2" (343mm) high x 29" (737mm) deep. 40,000 BTU (11.72 kW) cast iron oven burner. Stainless steel front with black powder coat epoxy sides. 139,000 BTU (40.73 kW) total. Natural or propane gas. AGA, CGA certified and NSF listed. (Also available with storage base with doors, Model M48S, and modular top, Model M48T.)



Garland Commercial Industries, Inc.
185 East South Street
Freeland, Pennsylvania 18224
Phone: (570) 636-1000
Fax: (570) 636-3903

Garland Commercial Ranges Ltd
1177 Kamato Road, Mississauga, Ontario
L4W 1X4 CANADA
Phone: 905-624-0260
Fax: 905-624-5669

Enodis UK LTD
Swallowfield Way, Hayes, Middlesex
UB3 1DQ ENGLAND
Telephone: 081-561-0433
Fax: 081-848-0041



Item #: _____
 Models: M48R, M48S, M48T
 Product Name: Master Series Thermostat
 Controlled Griddle-Top Range

Product	Width: In(mm)	Depth: In(mm)	Height: In(mm) (w/ NSF Legs)	Height: In(mm) (w/o NSF Legs)	Oven/Storage Base Interior: in(mm)		
					Width	Depth	Height
M48R	34(864)	38(965)	36-3/8(924)	30-3/8(772)	26-1/4(667)	29(737)**	13-1/2(343)
M48S	34(864)	38(965)	36-3/8(924)	36-3/8(924)	26(665)	30-1/2(773)	20-1/2(519)
M48T	34(864)	38(965)	36-3/8(924) w/stand	6-7/8 (175) w/o stand*	N/A	N/A	N/A

*Modular top has 1-1/2" seating flanges. **RC oven is 25"(635mm) deep. **NOTE:** MS48T & MST48T are 9-1/2" (241mm) high

INPUT-BTU/hr (Natural Gas)	M48R	kW Equivalent	M48S	kW Equivalent	M48T	kW Equivalent
Top Section	99,000	29.00	99,000	29.00	99,000	29.00
Oven	40,000	11.72	N/A	-	N/A	-
TOTAL	139,000	40.72	99,000	29.00	99,000	29.00

RC=Range w/Convection Oven R=Range w/Oven S=Range w/Storage Base T=Modular Top

INSTALLATION NOTES			Shipping Wt: (Lb/Kg)	
Combustible Wall Clearances ¹ Sides: 14" (356mm) Back: 6" (152mm)	Entry Clearances Crated: 39-1/4" (997mm) Uncrated: 34-1/4" (870mm)	Manifold Pressure Natural: 6" WC (15mbar) Propane: 10" WC (25mbar)	M48R	600/273
			M48S	500/227
			M48T	410/186

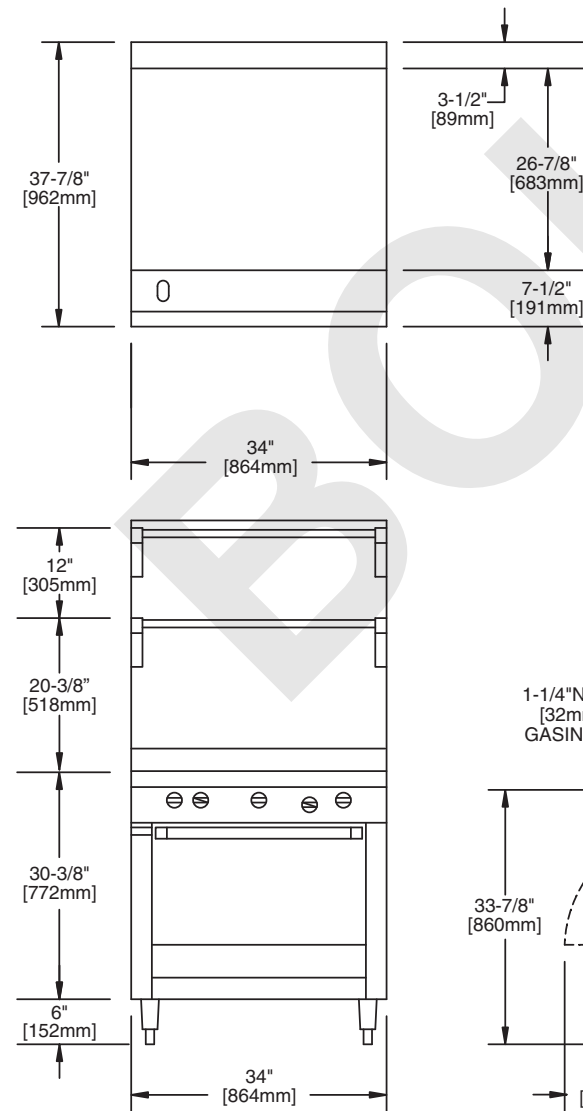

¹NOTE: Installation clearance reductions are applicable only where local codes permit.

Data applies only to North America

Gas input ratings shown here are for installations up to 2,000 ft. (610m) above sea level. Specify altitudes over 2,000 ft.

Commercial cooking equipment requires an adequate ventilation system. For additional information, refer to the National Fire Protection Association's standard NFPA96. (for North America only)

Electrical characteristics each RC oven: 1/3 HP motor, 120 VAC, single phase, 3.4 amps, 6 ft. (1.8m) power supply cord provided. 230 VAC export is direct connect, single phase, 50 Hz.

Please specify gas type when ordering.

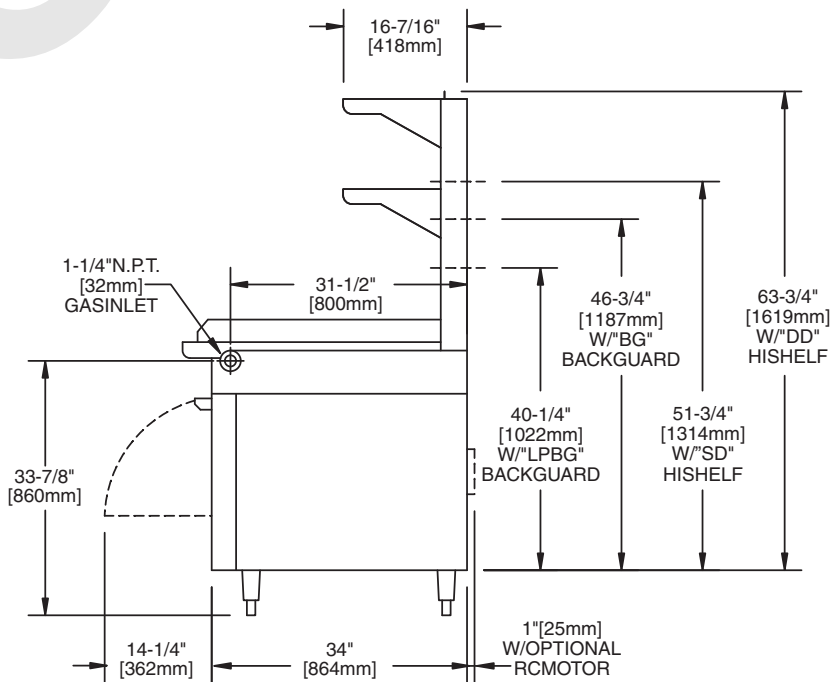

Continuous product improvement is a Garland policy.