

Specification:

Heavy-duty range-match gas fryer, Model # M70SS. 125,000 BTU, (36.62 kW), infra-red jettype burner, 70 lb., (32 kg), capacity. Stainless steel fry pot. 24" (612mm) wide x 38" (965mm) deep, including 8-1/4" (210mm) deep stainless steel front rail. Stainless steel front with black powder coat epoxy sides. Natural or Propane gas. AGA, CGA certified and NSF listed. MST prefix models carry CE mark for Europe.

Standard Features:

- Stainless steel front; black powder coat epoxy sides
- 6" (152mm) chrome steel adjustable legs
- 70 lb. (32kg) capacity, heavy-gauge, stainless steel frypot
- Twin chrome-wire baskets
- Infra-red jet-type burner 125,000 BTU (36.62 kW) total
- Built-in pressure regulator
- Piezo spark ignition with constant burning, 100% safety pilot
- One year limited parts & labor warranty, (USA and Canada only)

Optional Features:

- Stainless steel left, right or both sides.
- Stainless steel main back
- Stainless steel common front rail up to 68" (1728mm) wide, (two or more units in a battery)
- End caps and cover (no charge) - please specify
- Swivel casters (4) w/front brakes
- Polyurethane non-marking swivel casters (4) w/front brakes
- 6" (152mm) stainless steel adjustable legs
- 4" (102mm) chrome steel adjustable legs
- Additional fry baskets
- Stainless steel frypot cover
- Stainless steel fish plate
- Drain shelves
- 10" (254mm) high stainless steel backguard
- 17" (432mm) high stainless steel backguard
- 33" (838mm) high stainless steel backguard

NOTE: Fryers supplied with casters must be installed with an approved restraining device.



Item #: _____
 Model: M70SS
 Product Name: Master Series Heavy-Duty Gas Fryer

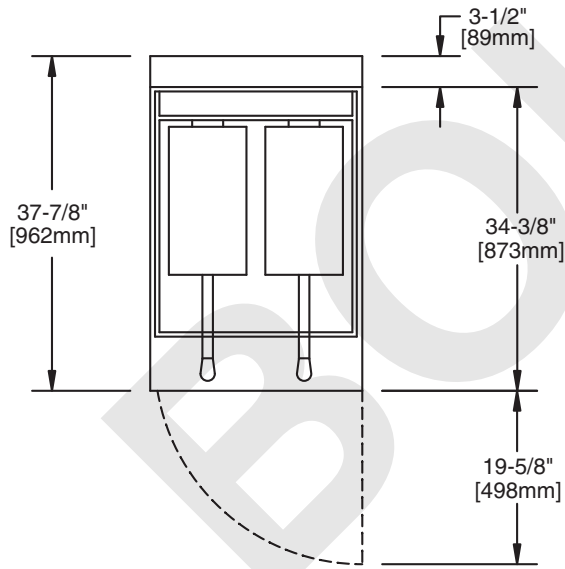
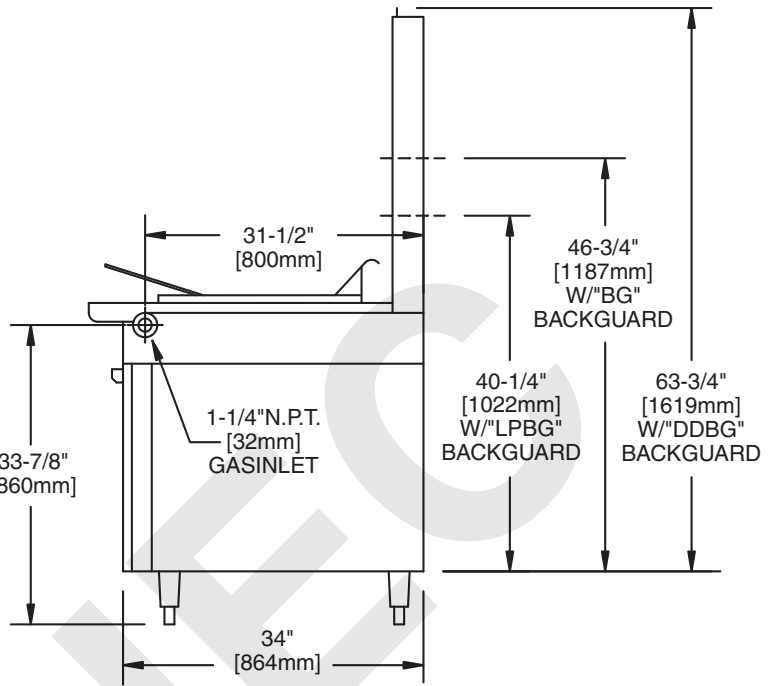
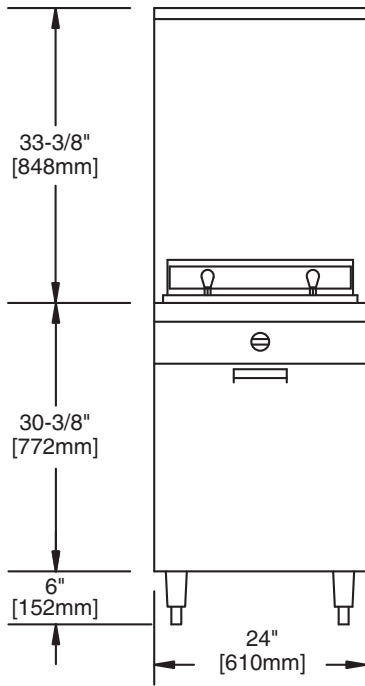

DIMENSIONS & SPECIFICATIONS	
Width	24" (612mm)
Depth	38" (965mm)
Height (w/ NSF Legs)	36-3/8" (924mm)
Height (w/o NSF Legs)	30-3/8" (772mm)
Input-BTU (Natural Gas)	125,000 (36.62 kW)
Shipping WT:(LB/KG)	225(120.5)

Gas input ratings shown here are for installations up to 2,000 ft. (610m) above seal level. Specify altitudes over 2,000 ft.
 Commercial cooking equipment requires an adequate ventilation system. For additional information, refer to the National Fire Protection Association's standard NFPA96. (for North American only)
 Please specify gas type when ordering
 Note: DDHS not recommended for use over fryer: use backguard only.

INSTALLATION NOTES		
Combustible Wall Clearances ¹	Entry Clearances	Manifold Pressure
Sides: 6" (152mm) Back: 6" (152mm)	Crated: 29-1/4" (997mm) Uncrated: 17-1/4" (438mm)	Natural: 6" WC (15mbar) Propane: 10" WC (25mbar)

¹NOTE: Installation clearance reductions are applicable only where local codes permit its.

NOTE: Data applies only to North America

PRODUCTION CHART: Frying Capacities (per hour)			
French Fries		Fish	Breaded Chicken
Raw to Finish 70 lb (32 kg)	Blanched to Finish 95 lb (43 kg)	3 oz Battered 100 lb (45 kg)	Raw to Done 28 lb (13 kg)