



Item #: _____

Model: E24-31SF & E24-31F

Product Name: E24 Series Heavy Duty Fryers



Model 24-31SF

Specification:

Garland E24 Series heavy-duty counter fryers are designed and engineered for high volume fast food operations. Model E24-31SF super fryer is for use where speed and recovery are of prime importance, preheats to 350° F (177°C) in less than 5 minutes, and model E24-31F fryer is for where speed and recover of the super fryer is not required, preheats to 350° F (177°C) in 6 ½ minutes. 200°F (93°C) to 375°F (190°C) hydraulic thermostat with recovery signal light, additional fail safe control turns fryer off if thermostat or contactor fail. Both models are designed to as freestanding units or bank with other E24 series equipment or with G24 series gas counter equipment. Stainless steel front and black powder coat epoxy sides, 18" (457mm) wide x 29" (710mm) deep x 12-3/8" (314mm) high. Single unit metal sheath immersion elements give even heat to sides, back and bottom of tank. Heating elements swing up to permit removal of the one piece drawn steel nickel plated finish fry tank with heavy steel handles, handles also support baskets for draining. Tank capacity is 30 lbs. (13.5 kg). Twin nickel-plated perforated baskets are standard.

Standard Features:

- Stainless steel front
- Black powder coat epoxy sides
- Twin nickle-plated perforated baskets
- 30 Lb (13.5Kg) capacity nickel plated steel tank with heavy duty steel handles
- 4" (102mm) Sanitary legs
- Recovery signal light
- Single unit sheath immersion elements that swing up
- 200°F (93°C) to 375°F (190°C) hydraulic thermostat
- Fail safe control with red flashing pilot light
- One-Year limited parts & labor warranty

Optional Features:

- Large single basket in lieu of twin baskets, NC
- Additional fryer tank available with or with out drain valve specify at time of order
- Stainless steel body sides
- Stainless steel back
- Stainless steel fryer bowl cover
- Stainless steel perforated fish plate
- Additional fry tank, lift out tank may be supplied with-out drain, please specify.

Optional CS24 Series Stands:

- Floor Stands: Heavy-duty stands of open design with seamless welded square tube legs. Black finish Storage shelf supplied with stands up to 48" (1219mm) wide. Working height of all units on stands 35-1/2" (902mm) Stand widths available in 15" (381 mm), 18" (457mm), 24" (610mm), 30" (762mm), 36" (914mm), 48" (1219 mm), 60" (1524mm) and 72" (1829mm). Example for E24-31F fryer, specify compatible CS24-18 stand.
 - Optional: Stainless steel finish add suffix SS
 - Swivel casters W/front brakes; set of 4



Garland Commercial Industries, Inc.
185 East South Street
Freeland, Pennsylvania 18224
Phone: (570) 636-1000
Fax: (570) 636-3903

Garland Commercial Ranges Ltd
1177 Kamato Road, Mississauga, Ontario
L4W 1X4 CANADA
Phone: 905-624-0260
Fax: 905-624-5669

Enodis UK LTD
Swallowfield Way, Hayes, Middlesex
UB3 1DQ ENGLAND
Telephone: 081-561-0433
Fax: 081-848-0041

LOADING CHART									
Model	Total Kw Load	Nominal Amperes Per Line							
		3 Phase						Single Phase	
		240V			208V			240V	208V
		X	Y	Z	X	Y	Z		
E24-31F	12	29.0	29.0	29.0	33.5	33.5	33.5	50.0	58.0
E24-31SF	16	42.0	33.0	42.0	48.0	38.0	48.0	67.0	77.0

Export voltage available on request – Specify wiring required

kW loadings are reduced on 220 volt systems.

Standard wiring 240 volt (220/240) or 208 volt (197/219) single or three phase – **Specify which is required**

FRYER CAPACITY in Lbs/Kg									
Model	French Fried Potatoes				Chicken		Fish Breaded		
	Raw to Finish		Frozen Blanched to Finish		Raw to Finish		2 Oz, (56g)		
	Load	Hourly	Load	Hourly	Load	Hourly	Load	Hourly	
E24-31F	6/2.7	60/27	6/2.7	88/40	3.6/1.6	36/16	3.5/1.6	105/47	
E24-31SF	6/2.7	80/36	6/2.7	118/53	3.5/1.5	42/19	3.5/1.6	116/52	

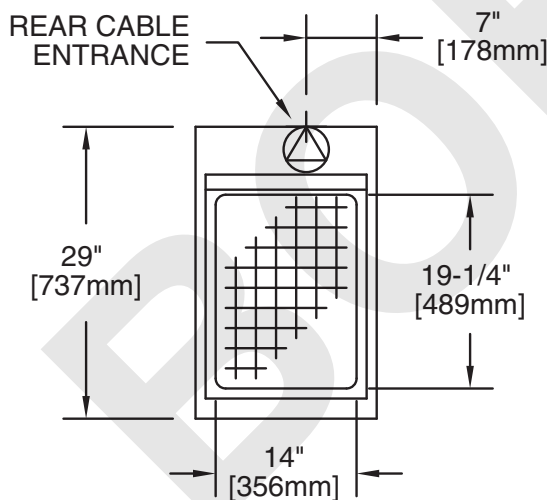

Model	Overall Dimensions			Shipping Wt. Lb/kg
	Height	Width	Depth	
All Models	12-3/8" (737mm)	18" (457mm)	29" (737mm)	60/27

NOTE: N.F.P.A Requirement - Fryers shall be installed at least 16" (406mm) away from surface flame cooking equipment in accordance with local law.

Installation Clearances	
Side	Rear
0	0)

NOTE: Add 4" (102mm) to height if sanitary legs are used.

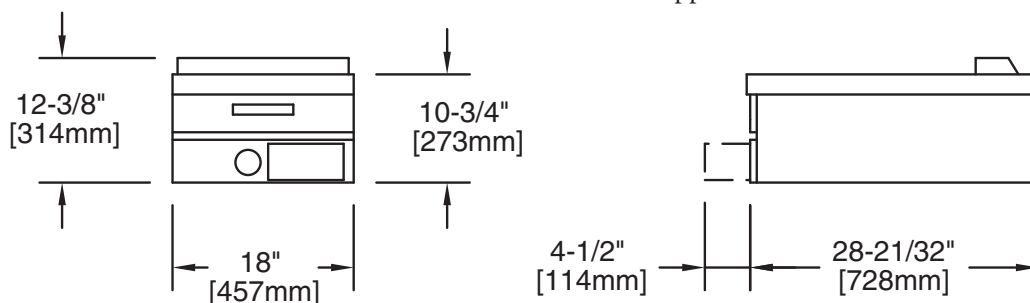

Garland products are not approved or authorized for home or residential use, but are intended for commercial applications only. Garland will not provide service, warranty, maintenance or support of any kind other than in commercial applications.

Continuous product improvement is a Garland policy. Specifications and design are subject to change without notice.