

PRODUCT:

QUANTITY:

ITEM#:

Designed Smart.

CWK-1 Kettle Cooker/Warmer

- CWK-1 Kettle utilizes a bottom mounted heating element and an aluminum transfer plate to provide consistent heat.
- Thermostatically controlled heat can reach temperatures up to 350° degrees.
- Provided with insulation to protect interior parts and countertops from heat build-up.
- Unit is designed to be used with water, but will be damaged if it runs dry.

WK-1 Kettle Warmer

- WK-1 Kettle utilizes a bottom mounted heating element and an aluminum transfer plate to provide consistent heat.

**COUNTERTOP ROUND KETTLE SERVERS**

Built Solid.

Built to Last

- Kettles are made of a high strength aluminum exterior.

Reliability backed by the Industry's Best Warranty

- This APW Wyott Cooking Equipment is backed by a 1-year Parts and Labor warranty.



- Certified by the following agencies:

SANITATION
CLASSIFIED

APW Wyott Design Features

CWK-1 Kettle Cooker/Warmer

- 11-qt. capacity — converts to 7 qt. with adapter kit.
- Multi-functional — cooks, warms and serves soups, chowders, chili and sauces.
- Attractive ebony housing.
- Thermostatic control for accurate temperature regulation.
- Lightweight aluminum and stainless steel construction.

WK-1 Kettle Warmer

- 11 qt. capacity; converts to 7 qt. with optional adapter ring.
- Sturdy aluminum construction.
- Insulated to maintain steady 160°–170° temperature.
- Indispensable countertop item.

Options

- 7 quart adaptor ring. (55708)
- Optional inset, flat cover and colorful soup merchandising cards available.

PRODUCT:

QUANTITY:

ITEM#:

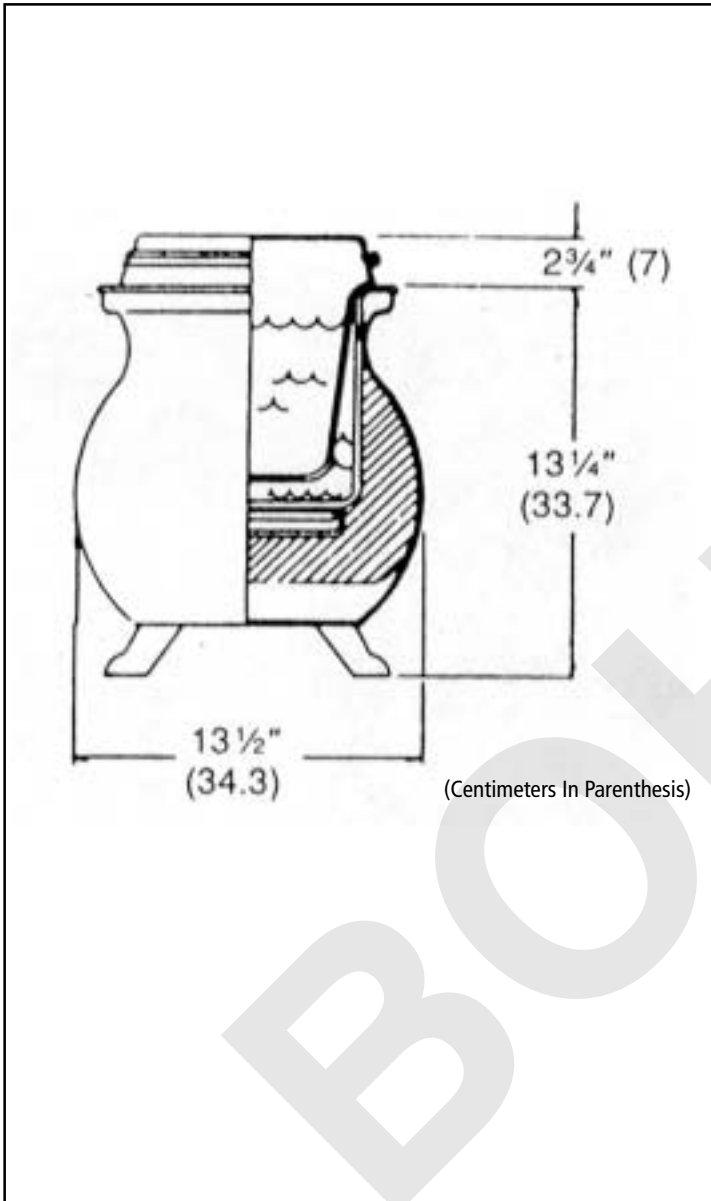

Model WK-1 & CWK-1 Round Warmer

PRODUCT SPECIFICATIONS

Construction:

Crafted of heavy gauge aluminum. Fiberglass insulated

Dimensions: (with inset)

WK-1: 16" H x 13 1/2" Dia. (40.6 cm x 34.3 cm)

CWK-1: 16" H x 13 1/2" Dia. (40.6 cm x 34.3 cm)

Electrical Information:

Each unit is equipped with a 60", three wire grounded power cord which terminates with a standard three pronged male plug. The 120 V unit uses a NEMA 5-15P plug. The WK-1 240V unit comes with NEMA 6-15P 90° plug. The CWK-1 240V unit comes with plug end cut off.

Electrical Specifications:

WK-1: 120V, 500W, 4.2 Amps

240V, 660W, 2.7Amps

CWK-1: 120V, 800W, 6.7 Amps

240V, 800W, 3.3 Amps

Capacity:

11 qts. (10.4 L)

Converts to 7 qt. with No. 55708 adapter ring.

Ship Weight:

WK-1: 20 lbs. (9.1 kg) with inset

16 lbs. (7.3 kg) without inset

CWK-1: 20 lbs. (9.1 kg) with inset

16 lbs. (7.3 kg) without inset

F.O.B./ Dallas, TX

World Class Support

World Class Sales Support to assist you with finding the right solution to your operation's needs. Call Customer Service at (800) 527- 2100 or Fax your request to 1-(214) 565-0976.

For more information about APW Wyott's World Class Support and High Performance Equipment, look us up on the Internet at www.APWwyott.com

Most Extensive Service System in the Industry! APW Wyott has two levels of service support for your needs:

- Direct Service Hot Line to Service Department, call (800) 527-2100.
- To find the Registered Service Technician in your area, call Automated Service Hot Line at (800) 733-2203.