

damos color a sus sueños y vida a sus proyectos
we give colour to your dreams and life to your projects

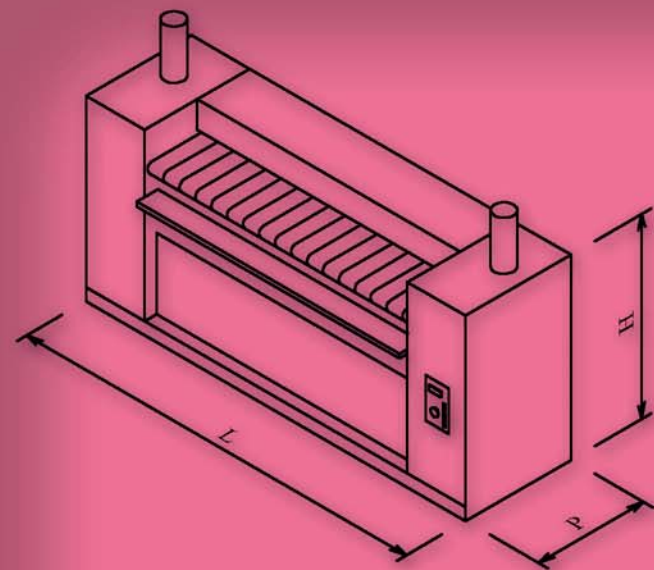

A- Conexión eléctrica A- Electric connection
E- Salida vahos E- Exhaust

MODELO	MODEL	CM e1420	1432	1632	2032	1950	2550	3250	
PRODUCCIÓN 45% HUMEDAD	OUTPUT 45% MOISTURE	Kg/h	12-14	15	22	32	50	70	92
RODILLO	ROLLER								
Diámetro Ø	Diameter Ø	mm	200	325	325	325	500	500	500
Longitud	Length	mm	1400	1400	1600	2000	1900	2500	3200
Velocidad planchado	Ironing speed	m/min	1-5	1-6,5	1-6,5	1-6,5	1-8	1-8	1-8
CALEFACCIÓN / CONSUMOS	HEATING / POWER CONSUM.								
Potencia eléctrica	Electric power	Kw	10,5	12	16	20	31,5	40,5	54
Potencia gas (prop./nat.)	Gas power (prop./nat.)	Kcal/h	-	12040	19350	25800	34400	47300	59350
Presión gas (prop./nat.)	Gas pressure (prop./nat.)	mbar	-	37/20	37/20	37/20	37/20	37/20	37/20
Consumo vapor (8bars)	Steam consumption (8bar)	Kg/h	-	-	-	-	67	90	113
Presión vapor	Steam pressure	bar	-	-	-	-	10	10	10
Volumen extracción aire	Air- extraction volume	m3/h	120	500	500	1000	600/1200	1200	1200
POTENCIAS	POWER RATINGS								
Potencia motor	Power motor	Kw	0,23	0,37	0,37	0,49	0,87	0,87	0,87
Motor (mod. CMP plegador)	Engine (folder CMP mod.)	Kw	-	-	-	-	1,55	1,55	1,55
CONEXIONES	CONNECTIONS								
Gas Ø (B)	Gas Ø (B)	BSP	-	3/4"	3/4"	3/4"	3/4"	3/4"	3/4"
Vapor Ø (C)	Steam Ø (C)	BSP	-	-	-	-	3/4"	3/4"	3/4"
Condensados Ø	Condensates (D)	BSP	-	-	-	-	1/2"	1/2"	1/2"
Salida de Vahos Ø (I)	Exhaust Ø (I)	mm	1x56	1x100	1x100	2x100	2x153	2x153	2x153
Aire comprimido Ø 6/7 Bar	Compressed air Ø 6/7 Bar	NL/h	-	-	-	-	15000	15000	15000
TENSIÓN	VOLTAGE		400 III+ 50 HZ . Opcional 230 III 50 HZ						
DIMENSIONES (Sin embalaje)	DIMENSIONS (Packing excluded)								
Ancho (L)	Width (L)	mm	1940	1942	2192	2542	2974	3574	4274
Profundidad (P)	Depth (P)	mm	500	660	660	660	1070	1070	1070
Altura (H)	Height (H)	mm	1200	1112	1112	1112	1170	1170	1170
Peso neto	Net weight	Kg	170	305	355	435	925	1200	1475
DIMENSIONES (Sin embalaje) + PLEGADOR	DIMENSIONS (Packing excluded)+ FOLDER								
Ancho (L)	Width (L)	mm	-	-	-	-	3164	3764	4464
Profundidad (P)	Depth (P)	mm	-	-	-	-	1300	1300	1300
Altura (H)	Height (H)	mm	-	-	-	-	1170	1170	1170
Peso neto	Net weight	Kg	-	-	-	-	1060	1380	1700

DOMUS se reserva el derecho de modificar sin previo aviso. / DOMUS reserves the right to change without notice.



DOMUS (Fábrica / Factory)
Energía, 12 - Pol. Ind. la Quintana
08504 Sant Julià de Vilatorrada - BCN
T+ 34 93 888 71 53 - F+ 34 93 888 76 63
Email: domus@domus.es - www.domus.es

DOMUS (Delegación Centro)
Silicio, Naves 1ª y 3ª
28850 Torrejón de Ardoz - MADRID
T+ 34 91 725 52 23 - F+ 34 91 676 15 18
Email: domus@domus.es - www.domus.es

diseny: www.simbiosis.com



CM

Calandras Murales (planchadora-secadora mural)
Flatwork dryer-ironers

1420/1432/1632/2032/1950/2550/3250

flatwork ironers - calandras



1420/1432/1632/2032/1950/2550/3250

CMP

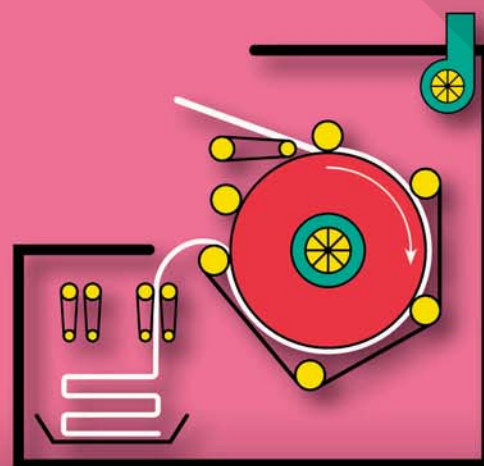

ALTA TECNOLOGÍA PARA LA MÁXIMA CALIDAD HIGH TECHNOLOGY FOR THE BEST QUALITY

Las calandras murales son el resultado de la experiencia y la tecnología de DOMUS, desarrollado en el proceso de planchado y secado.

Mural flatwork ironers are the result of DOMUS experience and technology, developed in the process of drying and ironing.

CARACTERÍSTICAS GENERALES

MAIN FEATURES

- ▶ **CALEFACCIÓN:**
Eléctrica, gas, vapor.
- ▶ **CONSTRUCCIÓN:**
Interior de la estructura en acero tratado y pulido.
La carrocería exterior de chapa de acero revestida de pintura poliéster.
Rodillo de construcción en acero pulido.
- ▶ **CONTROL:**
Mediante un potente microprocesador el cual nos permite controlar la velocidad y temperatura de secado.
- ▶ **FUNCIONAMIENTO:**
Introducción de la ropa directamente de la lavadora de alta velocidad, sin previo secado. (45% de humedad).
Entrada y salida de las prendas por la parte delantera con cajón recogedor.
Planchado mediante rodillo a presión y bandas Nomex.
- ▶ **VARIADOR DE FRECUENCIA:**
Nos permite regular la velocidad de planchado.
- ▶ **TEMPERATURA:**
Controlada automáticamente mediante termostato de rápida lectura y regulación.
- ▶ **SEGURIDAD:**
Barra de seguridad para protección de las manos según normas CE.
- ▶ **TIPOS DE CALANDRA:**
CM: Planchadora secadora.
CMP: Planchadora secadora con plegador longitudinal incorporado.
- ▶ **OPCIONALES:**
Rodillo cromado, Smart System control de velocidad automático según la humedad real de la ropa.

- ▶ **HEATING:**
Electric, gas, steam.
- ▶ **CONSTRUCTION:**
Interior of the structure in treated polished steel.
Exterior bodywork in sheet steel with polyester paint coating.
Roller constructed from polished steel.
- ▶ **CONTROL:**
By a powerful microprocessor that enables us to control the drying speed and temperatures.
- ▶ **OPERATION:**
Laundry loaded directly from the high speed washer extractor without previous drying. (45% of humidity).
Garment entry and exit from the front part with a collection drawer. Ironing by a preassured roller and Nomex bands.
- ▶ **FREQUENCY INVERTER:**
Allows us to regulate the ironing speed.
- ▶ **TEMPERATURE:**
Automatically controlled by a quick read and quick regulation thermostat.
- ▶ **SECURITY:**
Security protection bar for the hand as CE standards.
- ▶ **TYPES OF FLATWORK IRONERS:**
CM: Dryer-ironer.
CMP: Dryer-ironer with length folder included.
- ▶ **OPTIONAL:**
Chromed roller, Smart System speed automatic control according to the real moisture of the linen.

Sistema de seguridad según normativa vigente.

Safety mechanisms according to standards.

flatwork ironers - calandras